

Weight 7,450 lbs

**NOTES:** UNLESS OTHERWISE SPECIFIED.

1. CONCRETE SHALL HAVE A MINIMUM COMPRESSIVE STRENGTH F C= 5000 PSI AT 28 DAYS.
2. THE PORTLAND CEMENT USED IN THE PRECAST SECTIONS SHALL MEET THE REQUIREMENTS OF TYPE II/V HIGH SULFATE RESISTANT CEMENT IN ACCORDANCE WITH ASTM C-150.

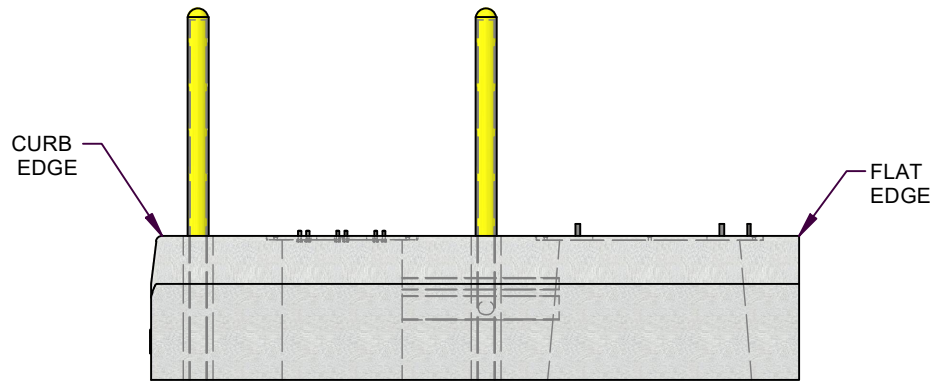
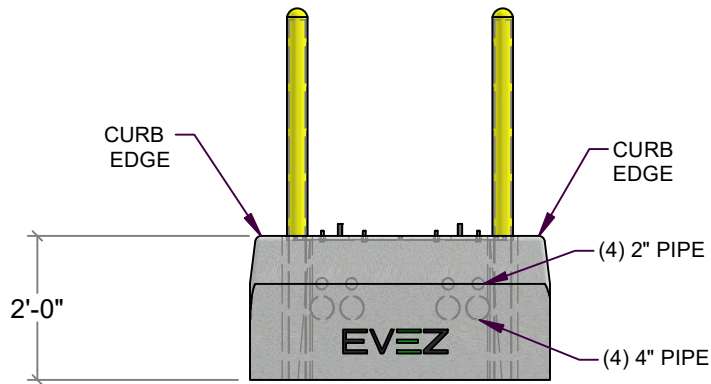
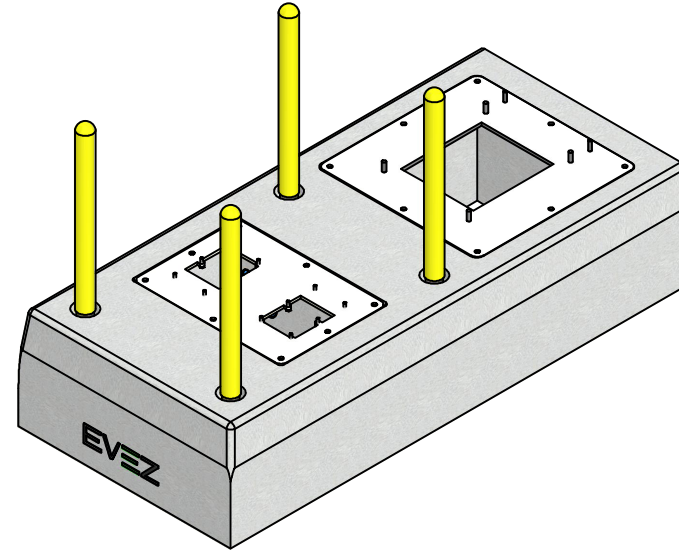
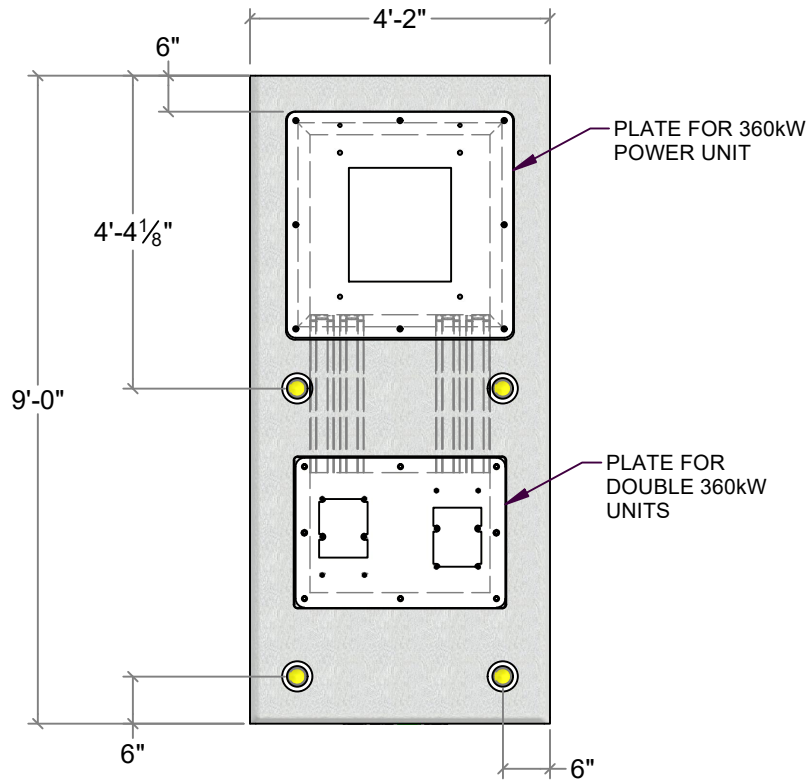

REVISIONS	No.	DATE	DESCRIPTION

THE CONTENTS OF THESE DRAWINGS ARE THE PROPERTY OF PRECON PRODUCTS AND ARE PROPRIETARY AND CONFIDENTIAL. THESE DOCUMENTS SHALL NOT BE DISSEMINATED FOR ANY OTHER USE, WITHOUT THE WRITTEN CONSENT OF PRECON PRODUCTS. IF YOU RECEIVE THESE DRAWINGS IN ERROR, RETURN TO SENDER WITHOUT READING, COPYING OR DISCLOSING THE CONTENTS.

DO NOT SCALE

240 W. LOS ANGELES AVE.  
SIMI VALLEY, CA 93065  
P: (805) 527-0841 F: (805) 584-0769  
WWW.PRE-CONPRODUCTS.COM

TITLE: EVEZ DOUBLE CHARGER AND POWER BASE FOR BTC UNIT

DRAWN BY: kstrader

DATE: 3/19/2024

SHEET: 1 OF 1