

PART INFORMATION

DESCRIPTION	QTY	APPROX. WEIGHT IN LBS
BP-1 BASE	1	5,500
8 5/8 OD STEEL BOLLARD TUBE AND COVER	1	N/A

NOTES: UNLESS OTHER WISE SPECIFIED

1. CONCRETE SHALL HAVE A MINIMUM COMPRESSIVE STRENGTH $F_c=5000$ PSI AT 28 DAYS.
2. THE PORTLAND CEMENT USED IN THE PRECAST SECTIONS SHALL MEET THE REQUIREMENTS OF TYPE II/V HIGH SULFATE RESISTANCE CEMENT IN ACCORDANCE WITH ASTM C-150.

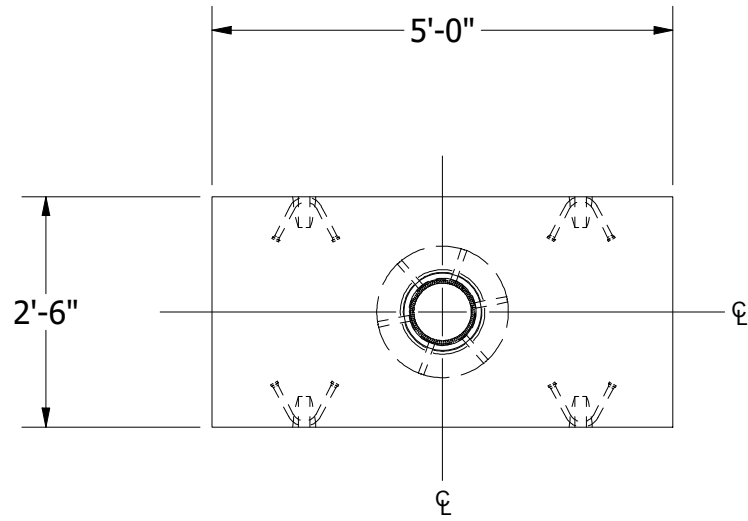

PLAN VIEW

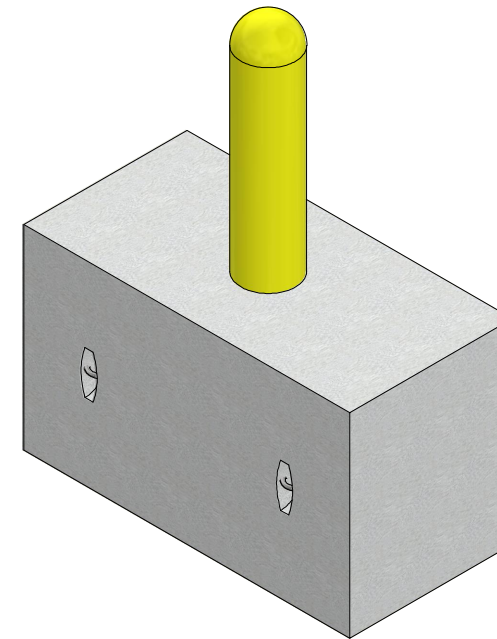

ISOMETRIC VIEW

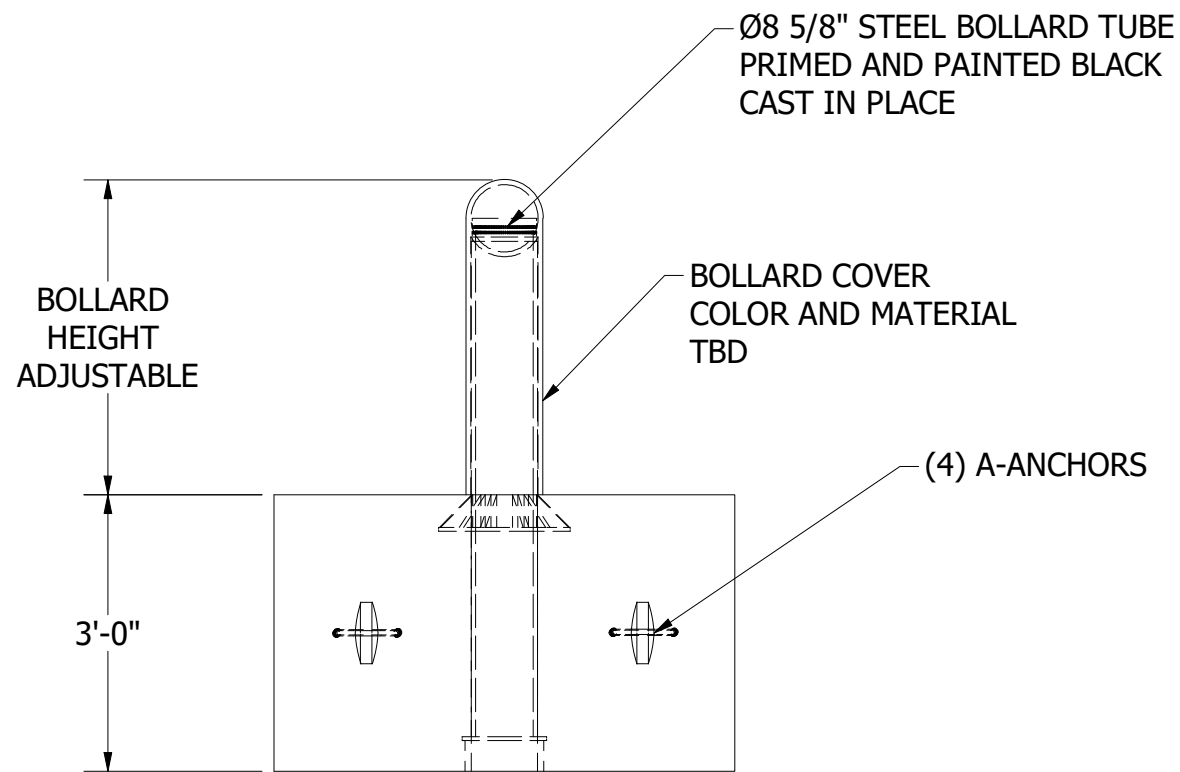

PROFILE VIEW

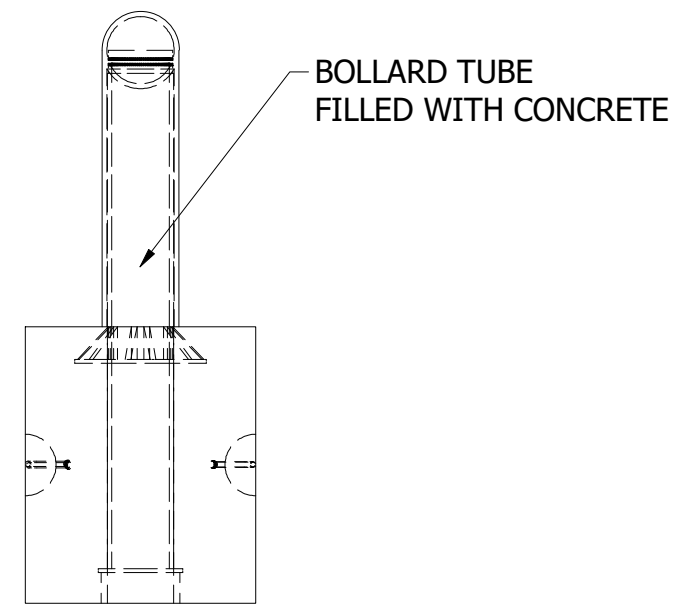

END VIEW

REVISIONS:
No. DATE DESCRIPTION

THE CONTENTS OF THESE DRAWINGS ARE THE PROPERTY OF PRECON PRODUCTS AND ARE PROPRIETARY AND CONFIDENTIAL. THESE DOCUMENTS SHALL NOT BE DISSEMINATED FOR ANY OTHER USE, WITHOUT THE WRITTEN CONSENT OF PRECON PRODUCTS. IF YOU RECEIVE THESE DRAWINGS IN ERROR, RETURN TO SENDER WITHOUT READING, COPYING OR DISCLOSING THE CONTENTS.

DO NOT SCALE

PRECON
240 W. LOS ANGELES AVE.
SIMI VALLEY, CA 93065
P: (805) 527-0841
WWW.PRE-CONPRODUCTS.COM

TITLE:
**SET AND POUR
1 BOLLARD BASE**

DRAWN BY:
W.TACK

DATE:
8/15/2023

SHEET:
1 OF 1