

PART INFORMATION		
DESCRIPTION	QTY	APPROX. WEIGHT IN LBS
BP-4-3ft SPACING BASE	1	15,000
BP-4-4ft SPACING BASE	/	18,300
BP-4-5ft SPACING BASE	/	21,700
8 5/8 OD STEEL BOLLARD TUBE AND COVER	4	N/A

**NOTES: UNLESS OTHERWISE SPECIFIED**  
 1. CONCRETE SHALL HAVE A MINIMUM COMPRESSIVE STRENGTH  $F_c=5000$  PSI AT 28 DAYS.  
 2. THE PORTLAND CEMENT USED IN THE PRECAST SECTIONS SHALL MEET THE REQUIREMENTS OF TYPE II/IV HIGH SULFATE RESISTANCE CEMENT IN ACCORDANCE WITH ASTM C-150.

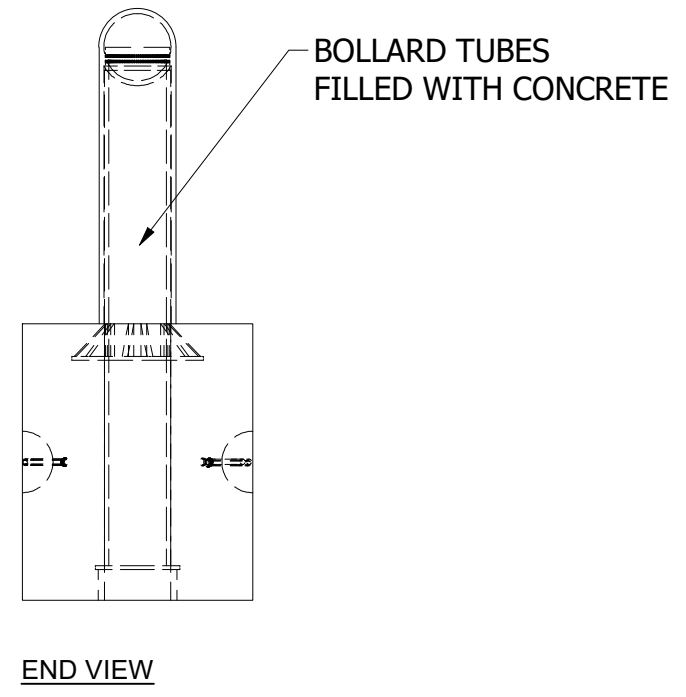
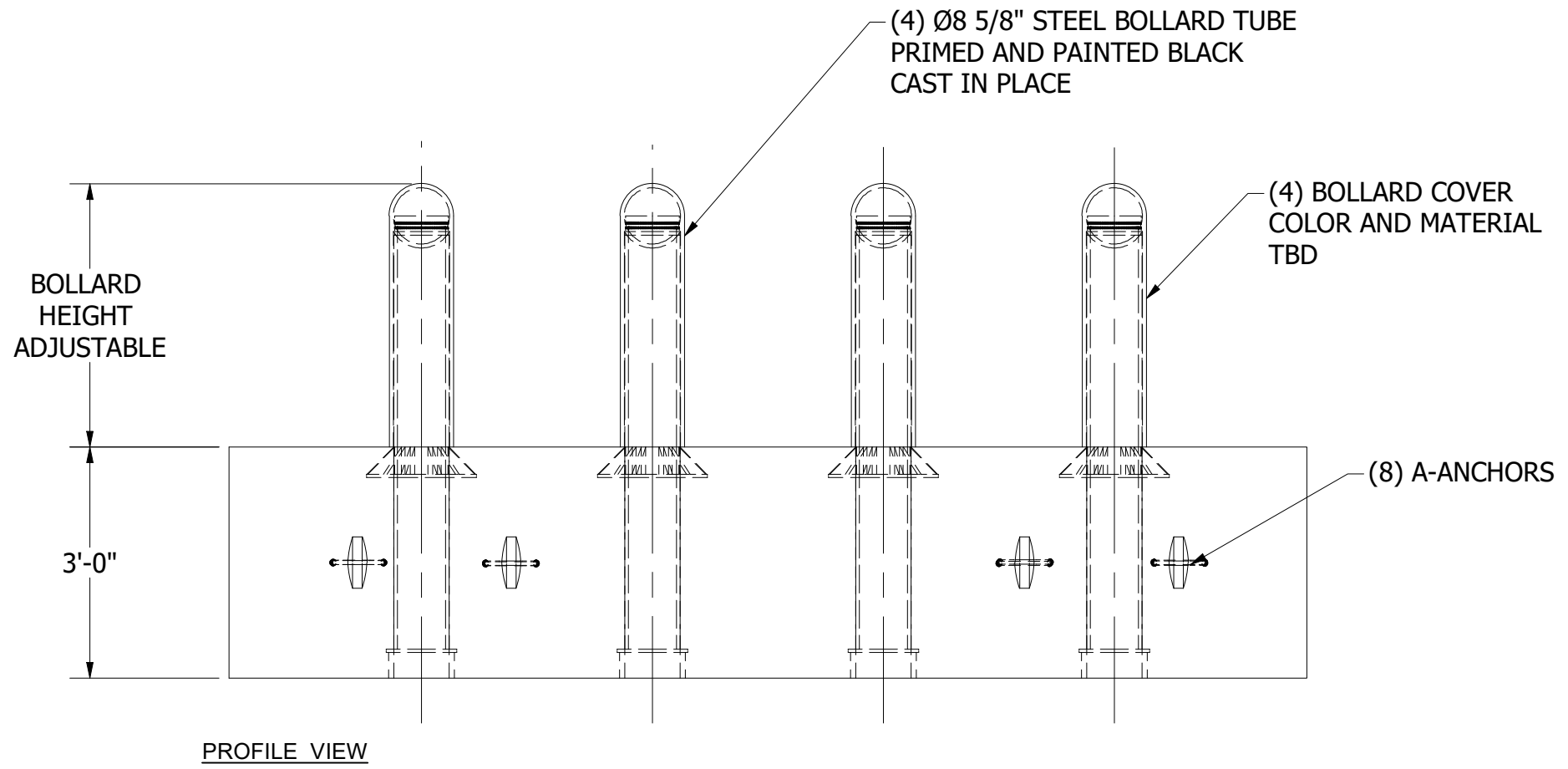
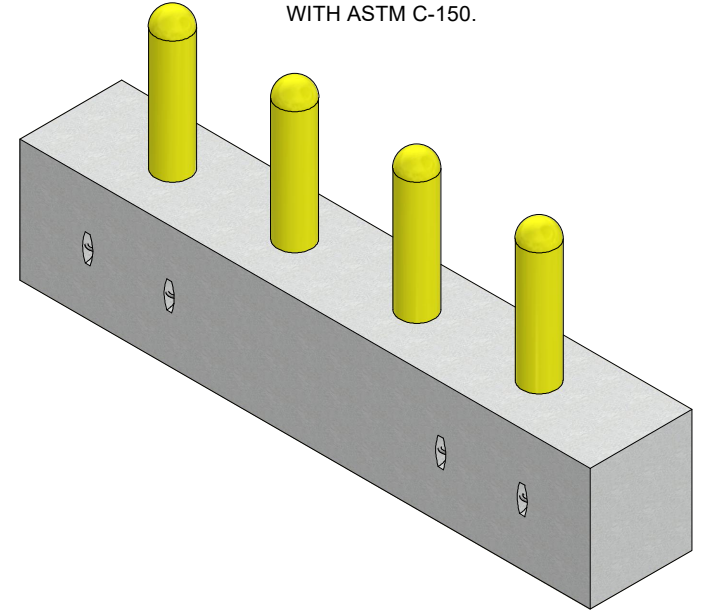
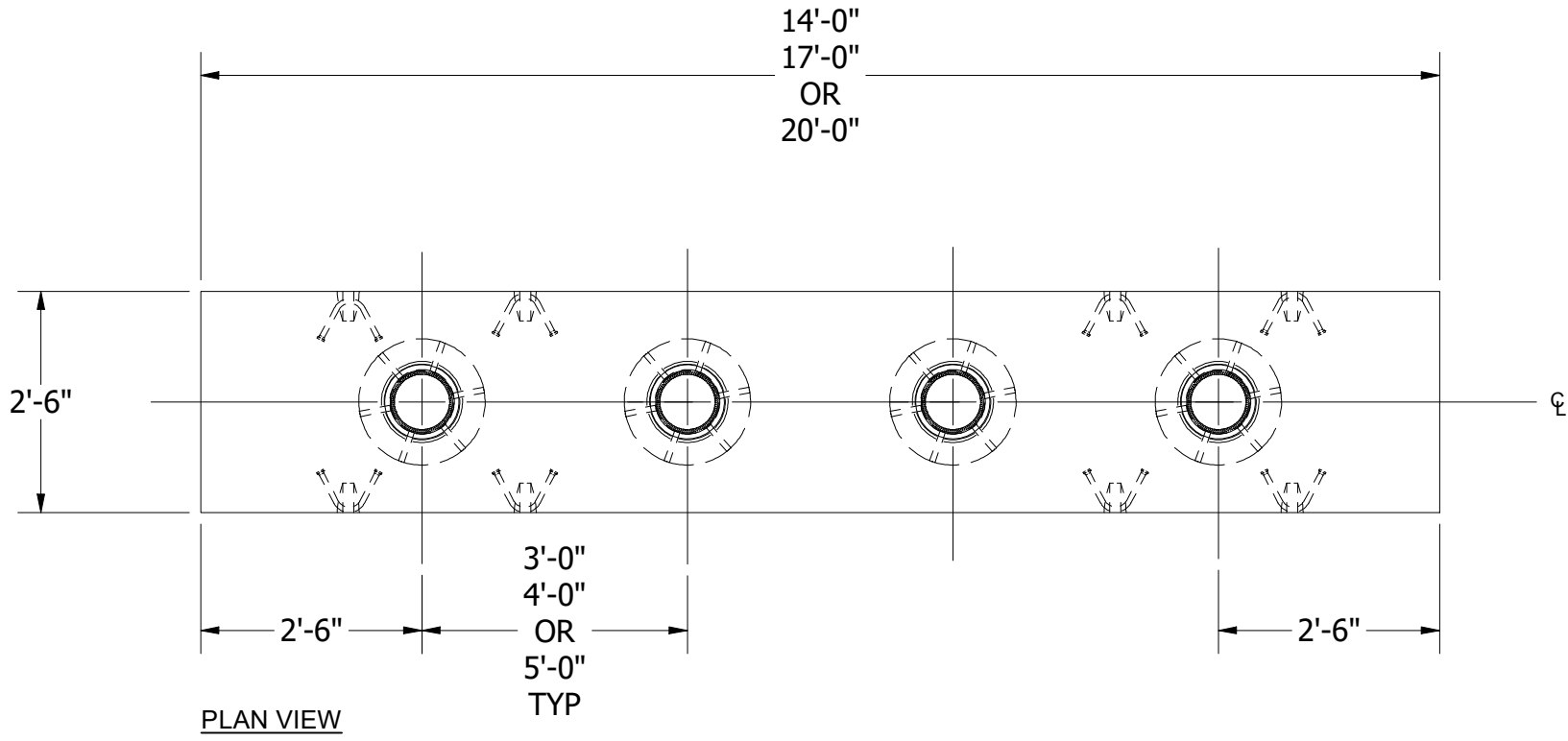

REVISIONS:  
 No. DATE DESCRIPTION

THE CONTENTS OF THESE DRAWINGS ARE THE PROPERTY OF PRECON PRODUCTS AND ARE PROPRIETARY AND CONFIDENTIAL. THESE DOCUMENTS SHALL NOT BE DISSEMINATED FOR ANY OTHER USE, WITHOUT THE WRITTEN CONSENT OF PRECON PRODUCTS. IF YOU RECEIVE THESE DRAWINGS IN ERROR, RETURN TO SENDER WITHOUT READING, COPYING OR DISCLOSURING THE CONTENTS.

DO NOT SCALE



TITLE:  
**SET AND POUR  
 4 BOLLARD BASE**

DRAWN BY:  
**W.TACK**

DATE:  
**8/15/2023**

SHEET:  
**1 OF 1**

LOCATION: T:\Drawings\Vault\DESIGNS\Foundation\Bollards\BP-4.dwg