

PART INFORMATION	
PART NUMBER	APPROX WEIGHT
WS-4	142 lbs

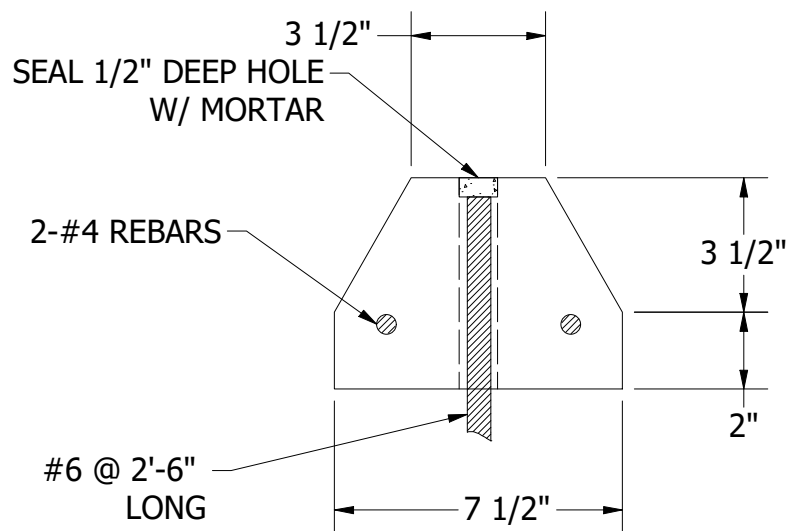

**NOTES: UNLESS OTHERWISE SPECIFIED.**

1. CONCRETE SHALL HAVE A MINIMUM COMPRESSIVE STRENGTH F<sub>C</sub> = 4000 PSI AT 28 DAYS.
2. THE PORTLAND CEMENT USED IN THE PRECAST SECTIONS SHALL MEET THE REQUIREMENTS OF TYPE II/V HIGH SULFATE RESISTANT CEMENT IN ACCORDANCE WITH ASTM C-150.

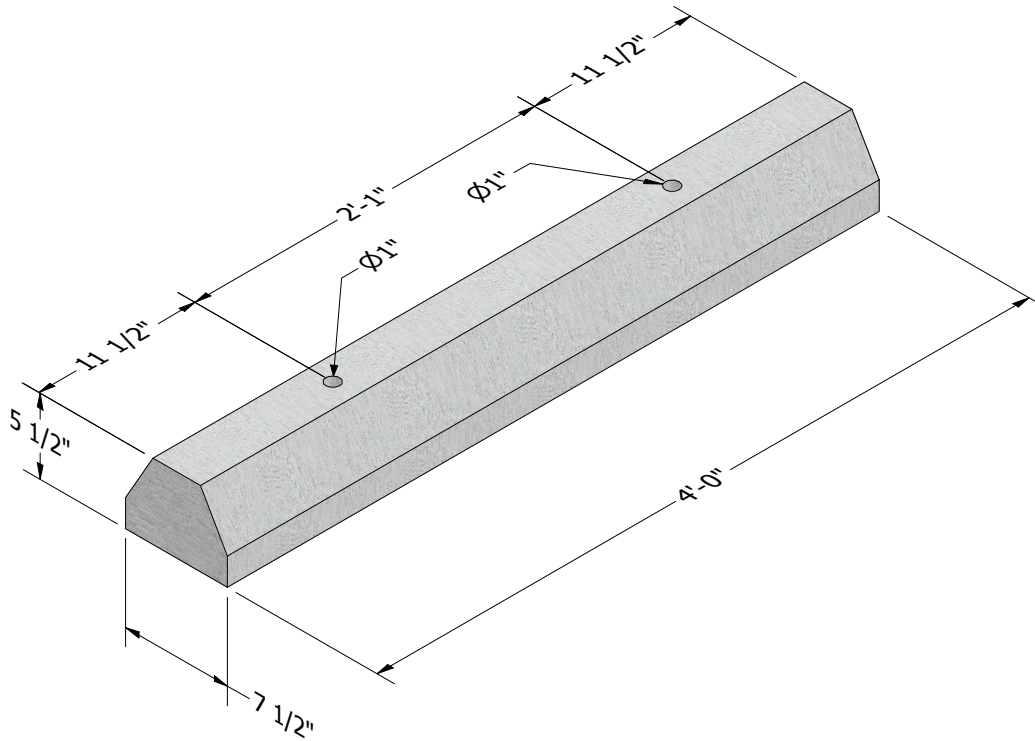

240 W. LOS ANGELESE AVE. SIMI VALLEY, CA 93065  
 P: (805) 527-0841 F: (805) 584-0769,  
 WWW.PRE-CONPRODUCTS.COM

THE CONTENTS OF THESE DRAWINGS ARE THE PROPERTY OF PRECON PRODUCTS AND ARE PROPRIETARY AND CONFIDENTIAL. THESE DOCUMENTS SHALL NOT BE DISSEMINATED FOR ANY OTHER USE, WITHOUT THE WRITTEN CONSENT OF PRECON PRODUCTS. IF YOU RECEIVE THESE DRAWINGS IN ERROR, RETURN TO SENDER WITHOUT READING, COPYING OR DISCLOSING THE CONTENTS.

DRAWN BY:  
**K.Strader**  
 DATE:  
 1/26/2022

TITLE:  
**PRECAST CONCRETE  
 WHEEL STOP 4'-0"**

SHEETS:  
 1 OF 1

DO NOT SCALE